

BRAKE SYSTEM**1997 BRAKES General Motors - Disc****DESCRIPTION & OPERATION**

Disc brakes are continually self-adjusting. Caliper piston seals retract pistons enough to allow brake pads to lightly brush rotor. Sliding caliper compensates for pad wear. Parking brake mechanism is part of rear caliper.

Red BRAKE warning light illuminates under the following conditions:

- Parking brake is not fully released.
- Fluid level in master cylinder reservoir is low.
- Ignition switch is in START (bulb check) position. Light should not come on with ignition switch in any other position.

An Amber brake pad wear warning indicator, located on instrument cluster, illuminates when front brake pads are worn and replacement is necessary. Indicator does not illuminate as a bulb check when ignition is turned on.

BLEEDING BRAKE SYSTEM

CAUTION: Because of brake fluid expansion due to heat absorbed from brakes and engine, DO NOT overfill master cylinder reservoir. DO NOT reuse brake fluid. Use only new, clean DOT 3 brake fluid. DO NOT use silicone DOT 5 brake fluid.

NOTE: Check brake fluid level frequently during bleeding procedure. Protect vehicle exterior paint from possible brake fluid spillage.

MANUAL BLEEDING

1. Deplete vacuum reserve from power brake booster by depressing brake pedal several times with engine off. Fill master cylinder reservoir and keep at least half full during bleeding procedure. Reinstall master cylinder reservoir cap. If master cylinder is not suspected of having air in bore, go to step 4). If master cylinder is known or suspected of having air in bore, go to next step.
2. Disconnect front EBTCM brakeline fitting at master cylinder. Allow fluid to flow from fitting. Tighten fitting to specification. See **TORQUE SPECIFICATIONS** . Have an assistant depress brake pedal slowly and hold. Ensure reservoir fluid level is maintained. Again, loosen front EBTCM brakeline fitting. Tighten fitting while pedal is still at floor. Release brake pedal slowly. Wait 15 seconds.

NOTE: Rapid pumping of brake pedal causes master cylinder secondary piston to move into a position that makes bleeding system difficult.

3. Repeat step 2), including 15 second wait, until fluid is clear and free of air bubbles. Repeat procedure at other (rearmost) EBTCM brakeline fitting on master cylinder. Master cylinder is now bled. If wheel calipers are not suspected to have air in them, it is not necessary to bleed them.
4. If wheel calipers are known or suspected to have air in them, raise and support vehicle. Remove bleeder valve cap from right rear wheel. Place proper size box end wrench over bleeder valve. Attach one end of clear tube over valve and submerge other end in container partially filled with clean brake fluid.
5. Have an assistant depress brake pedal slowly and hold. Loosen bleeder valve to purge air from caliper. Tighten bleeder valve to specification and slowly release brake pedal. See **TORQUE SPECIFICATIONS** . Wait 15 seconds. Repeat procedure, including 15 second wait, until all air is removed.

6. Remove tube and wrench. Install bleeder valve cap. Fill master cylinder reservoir with fluid. Proceed to left rear, right front and left front wheels in sequence. Ensure there is no sponginess in brake pedal and that BRAKE warning indicator is off.

ADJUSTMENTS

BRAKE PEDAL HEIGHT & FREE PLAY

Brake pedal height and free play is not adjustable.

BRAKELIGHT SWITCH

Brakelight switch is self-adjusting and will adjust when brake pedal returns to at-rest position. Brakelight switch actuating pin is driven into switch based on brake pedal position.

PARKING BRAKE

1. Position parking brake lever to 4th notch. Raise and support vehicle. Remove rear wheel assemblies. Remove exhaust muffler heat shields. Remove propeller shaft. Loosen parking brake lever shaft adjusting nut until rear parking brake levers at rear of backing plate are in at-rest position (facing towards rear of vehicle).
2. Measure and record length of exposed shaft from nut (number of threads). Clean and lubricate exposed threads on each side of adjusting nut. Turn adjusting nut on both rear parking brake self adjusters until both sets of parking brake shoes just contact parking brake rotor with no significant drag.
3. Install rear wheel assemblies. Tighten adjusting nut on parking brake lever shaft until braking occurs, yet wheels can still be turned. Parking brake is properly adjusted is rear wheels can still be turned with parking brake lever pulled to 4th notch, and full braking is achieved when pulled to 7th notch. Ensure braking is equal at both rear wheels.

TESTING

BRAKE WARNING INDICATOR INOPERATIVE

NOTE: See INSTRUMENT PANEL article in **ACCESSORIES & EQUIPMENT** section.

REMOVAL & INSTALLATION

FRONT BRAKE CALIPER

Removal

1. Remove and discard 2/3 of brake fluid from master cylinder reservoir to prevent overflow when servicing. Raise and support vehicle. Mark wheel in relation to hub. Remove front wheel.
2. If not completely removing caliper (such as for overhaul), go to next step. If completely removing caliper, remove bolt securing brake hose to caliper. Disconnect brake hose from caliper. Plug opening in brake hose and caliper to prevent fluid loss and contamination. Using a screwdriver, carefully pry brake wad wear sensor from brake pads.
3. Position "C" clamp with stationary end of clamp on caliper housing and threaded end on outboard pad. Tighten "C" clamp until piston is pushed into bore far enough to slide caliper off rotor. Remove "C" clamp.
4. Remove caliper guide bolts and bushings. Remove caliper. If brake hose is still connected to caliper, hang caliper by wire so brake hose will not be damaged. Remove pads from caliper.

Installation

1. Liberally coat inner diameter of bushings with silicone grease. Install caliper. Install caliper guide bolts and

- bushings. If bolts slide through bushings using hand pressure, go to step 3).
2. If bolts do not slide through bushings using hand pressure, remove bolts and bushings. Inspect caliper bores for corrosion. If corroded, remove corrosion using 1" (25.4 mm) diameter wheel cylinder honing brush. Clean bores with clean denatured alcohol. Install and lubricate bushings. Install caliper guide bolts.
 3. Tighten caliper guide bolts to specification. See **TORQUE SPECIFICATIONS** . If brake hose was not disconnected, go to next step. If brake hose was disconnected, connect brake hose to caliper. Tighten fitting bolt to specification. Bleed brake hydraulic system, and go to next step. See **BLEEDING BRAKE SYSTEM** .
 4. Apply brakes several times to seat pads. Install wheel, aligning marks made during removal. Tighten wheel lug nuts to specification. Fill brake fluid reservoir. Road-test vehicle.

FRONT BRAKE PADS

Removal

Remove caliper. See **FRONT BRAKE CALIPER** . Slid caliper off rotor and support with wire. Remove inner and outer pads from caliper.

Installation

Clean and lubricate brake caliper bracket mounting surfaces. Install inner and outer pads into caliper bracket. Install inner pad with insulator on inside of rotor facing caliper piston. To install remaining components, reverse removal procedure. Tighten bolts to specification. See **TORQUE SPECIFICATIONS** .

FRONT BRAKE ROTOR

Removal & Installation

Remove caliper and wire aside. See **FRONT BRAKE CALIPER** . Mark rotor in relation to hub for installation reference. Remove rotor set screw and remove rotor. To install, reverse removal procedure.

REAR BRAKE CALIPER

Removal

1. Remove and discard 2/3 of brake fluid from master cylinder reservoir to prevent overflow when servicing. Raise and support vehicle. Mark wheel in relation to hub. Remove rear wheel.
2. If not completely removing caliper (such as for overhaul), go to next step. If completely removing caliper, remove bolt securing brake hose to caliper. Disconnect brake hose from caliper. Plug opening in brake hose and caliper to prevent fluid loss and contamination.
3. Using screwdriver, carefully pry between rotor and each brake pad to bottom each piston in its bore. Remove caliper mounting bolts and remove caliper. If brake hose is still connected to caliper, hang caliper using wire so brake hose will not be damaged. Remove pads from caliper.

Installation

1. Install caliper. Install caliper mounting bolts. Tighten caliper mounting bolts to specification. See **TORQUE SPECIFICATIONS** . If brake hose was not disconnected, go to next step. If brake hose was disconnected, connect brake hose to caliper. Tighten fitting bolt to specification. Bleed brake hydraulic system, and go to next step. See **BLEEDING BRAKE SYSTEM** .
2. Apply brakes several times to seat pads. Install wheel, aligning marks made during removal. Tighten wheel lug nuts to specification. Fill brake fluid reservoir. Road-test vehicle.

REAR BRAKE PADS

Removal

Remove and discard 2/3 of brake fluid from master cylinder reservoir to prevent overflow when servicing. Raise and support vehicle. Remove rear wheel. Using screwdriver, carefully pry between rotor and each brake pad to bottom each piston in its bore. Using a punch, drive brake caliper retaining pins out through rear of caliper. Remove brake pad spring retainer. Remove inner and outer pads from caliper.

Installation

Install inner and outer pads into caliper. Using a punch, drive first brake caliper retaining pin into caliper and through brake pad from rear of caliper. Install brake pad spring retainer. Drive second brake caliper retaining pin into caliper and through brake pad from rear of caliper. Ensure both retaining pins are inserted through brake pads. To install remaining components, reverse removal procedure. Tighten bolts to specification. See **TORQUE SPECIFICATIONS** .

REAR BRAKE ROTOR**Removal & Installation**

Remove caliper and wire aside. See **REAR BRAKE CALIPER** . Release parking brake, if applied. Mark rotor in relation to hub for installation reference. Remove rotor set screw and remove rotor. To install, reverse removal procedure.

PARKING BRAKE SHOES

NOTE: Observe position of springs, adjuster assembly and brake shoes for reassembly reference.

Removal

1. Release parking brake, if applied. Raise and support vehicle. Mark wheel in relation to hub. Remove rear wheel. Remove rear brake rotor. See **REAR BRAKE ROTOR** .
2. Remove parking brake cable return spring from rear parking brake lever and backing plate. See **Fig. 1** . Remove parking brake cable from rear parking brake lever. Using brake spring pliers, remove parking brake shoe upper return spring from parking brake shoe. See **Fig. 2** . Remove parking brake adjuster. Using brake spring pliers, remove parking brake shoe lower return spring from parking brake shoe.
3. Rotate wheel bearing hub flange until largest cutout is centered over parking brake shoe hold-down spring. Using screwdriver, remove hold-down spring, retainer and pin. Remove parking brake shoe. Repeat procedure for opposite parking brake shoe.

Installation

To install, reverse removal procedure. Adjust parking brake. See PARKING BRAKE under **ADJUSTMENTS** . Lower vehicle.

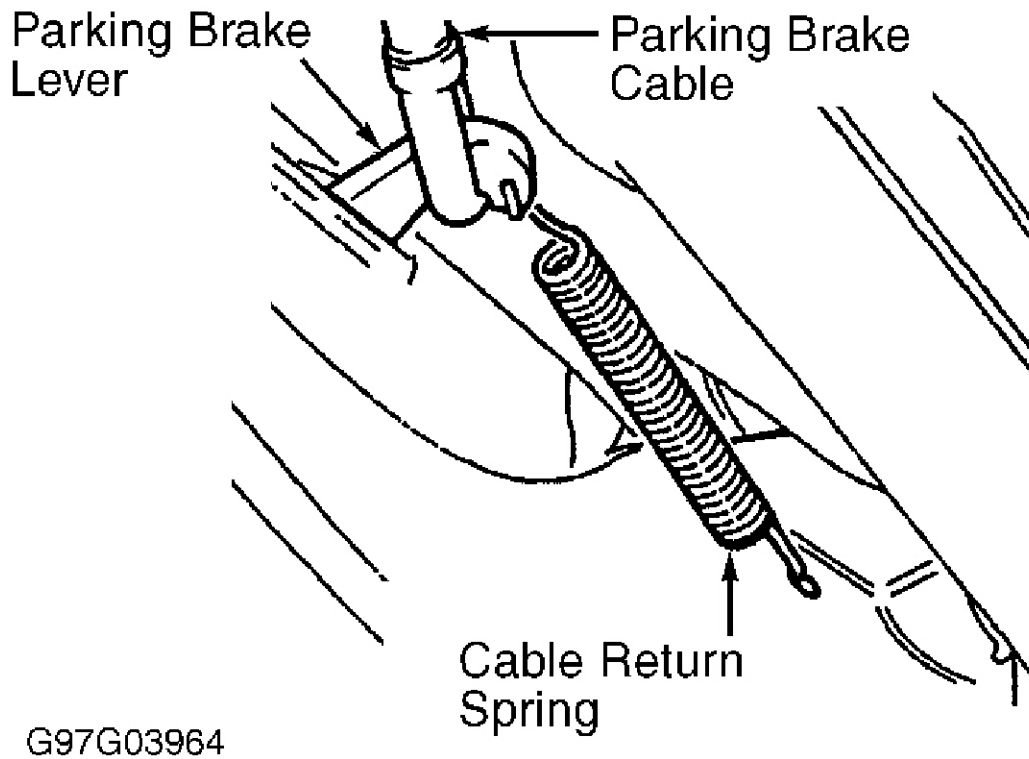

Fig. 1: Locating Parking Brake Cable
Courtesy of GENERAL MOTORS CORP.

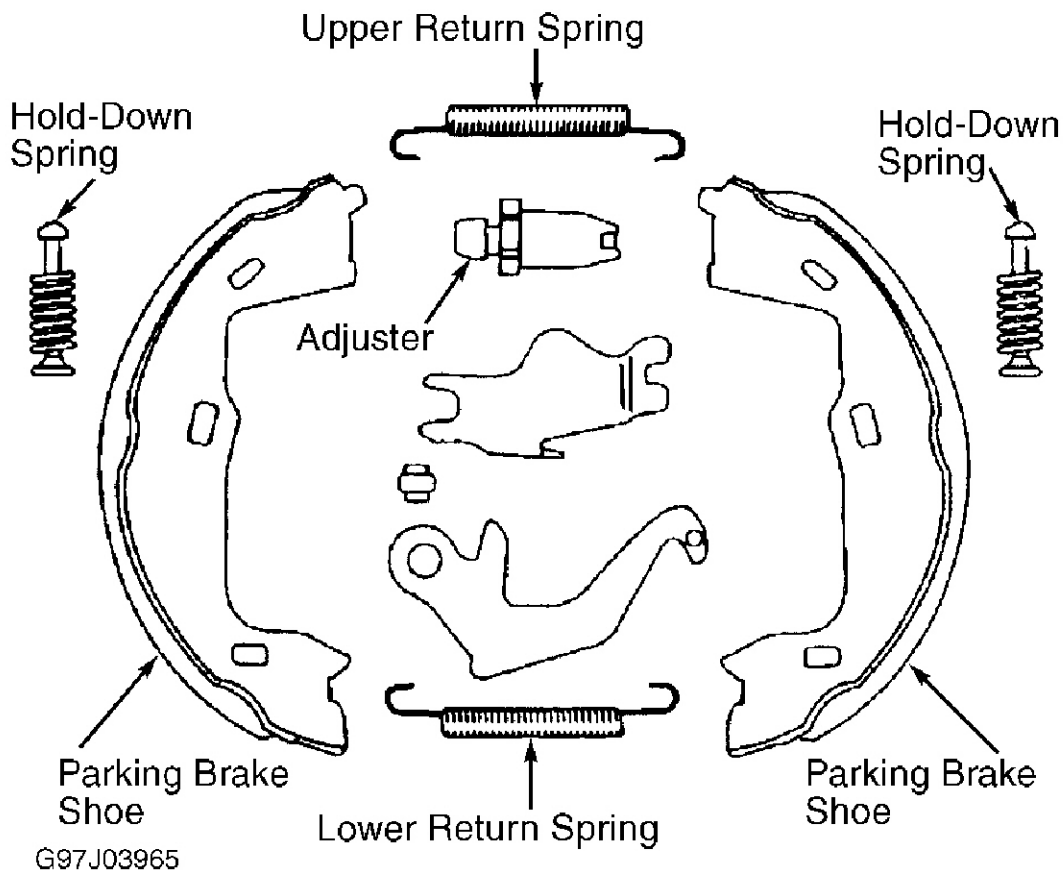

Fig. 2: Identifying Parking Brake Components
Courtesy of GENERAL MOTORS CORP.

MASTER CYLINDER & RESERVOIR**Removal**

1. Remove reservoir cap. Remove fluid from reservoir with a bulb syringe. While rocking back and forth, pulling up slightly to remove reservoir from master cylinder body. Remove power steering reservoir bracket bolt and remove bracket. Position power steering reservoir towards engine allowing access to master cylinder.
2. Disconnect and plug brakelines from master cylinder. Remove master cylinder nuts and remove master cylinder. Remove master cylinder seal.

Installation

To install, reverse removal procedure. Install NEW master cylinder seal. Lubricate NEW reservoir grommets with clean brake fluid and install on master cylinder. Bleed brake system. See **BLEEDING BRAKE SYSTEM** . Tighten master cylinder nuts and brakeline fittings to specification. See **TORQUE SPECIFICATIONS** .

POWER BRAKE BOOSTER

NOTE: **Power brake booster can be removed without removing master cylinder, but if both components are to be removed, remove master cylinder first.**

Removal

1. Remove windshield wiper motor and A/C evaporator line extension from firewall. Remove power steering reservoir bracket bolt and remove bracket. Position power steering reservoir towards engine, allowing access to master cylinder without disconnecting brakelines from master cylinder. Remove master cylinder from power booster and position aside.
2. Disconnect vacuum hose from power brake booster. Remove driver's side front floor air outlet duct. Remove brake pedal pivot pin retainer from pivot pin. Carefully, without disturbing pushrod clevis adjustment, press brake pedal pivot pin out of master cylinder pushrod clevis. Separate pushrod clevis from brake pedal.
3. Remove fuse/relay panel screws and position fuse/relay panel aside. Remove brake pedal bracket nuts. Remove power brake booster with gasket from bulkhead.

Installation

Before installing NEW power brake booster, measure distance between center of clevis and booster mounting flange. See **Fig. 3** . Distance should be 4.0-4.4" (101.6-111.8 mm). Tighten push rod adjusting nut. To install, reverse removal procedure. Tighten nuts to specification. See **TORQUE SPECIFICATIONS** . Adjust brakelight switch. See **BRAKELIGHT SWITCH** under ADJUSTMENTS.

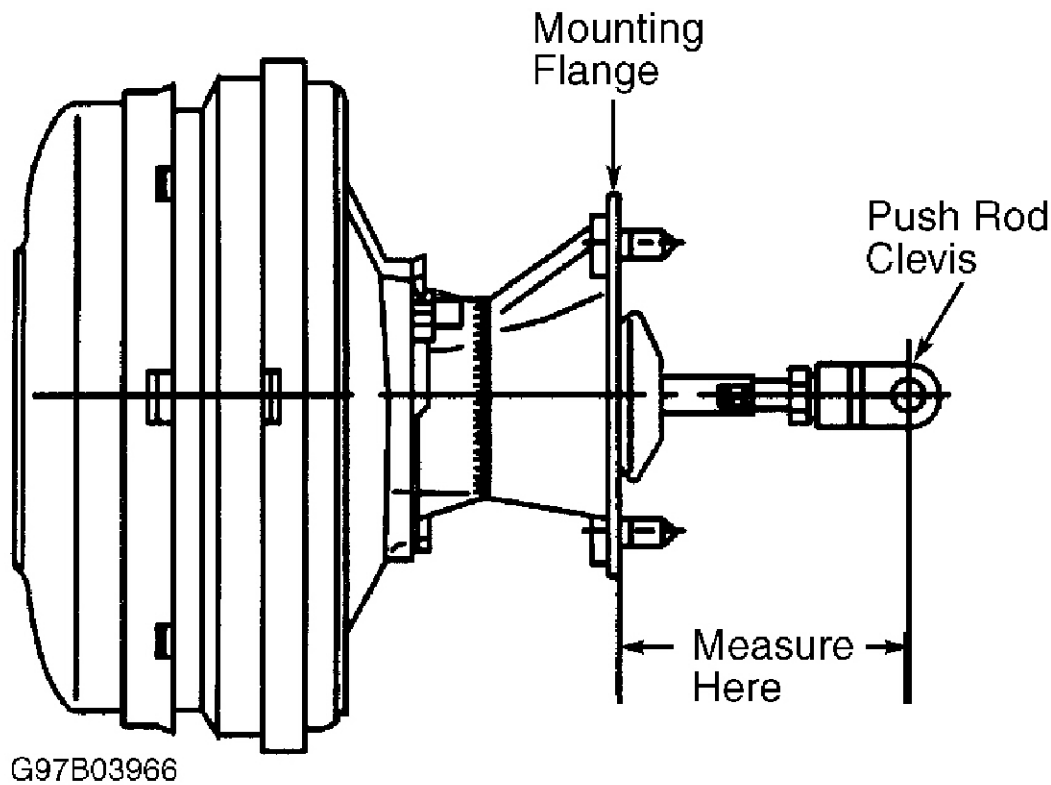

Fig. 3: Measuring Power Brake Booster Push Rod Installed Length
 Courtesy of GENERAL MOTORS CORP.

FRONT WHEEL HUB & BEARING ASSEMBLY

Removal

1. Raise and support vehicle. Remove front wheel. Remove brake pad wear indicator wire from strut bracket. Remove clip and separate brake hose from strut bracket. Remove brake caliper assembly and support aside. See **FRONT BRAKE CALIPER**. Remove rotor set screw and remove rotor. See **FRONT BRAKE ROTOR**.
2. Remove dust cap from wheel hub. Remove wheel hub nut. Remove wheel hub and bearing assembly.

Installation

To install, reverse removal procedure. Tighten nut to specification. See **TORQUE SPECIFICATIONS**.

REAR WHEEL HUB & BEARING ASSEMBLY

NOTE: See illustration for identification of tools necessary for rear wheel hub and bearing assembly removal and installation. See **Fig. 4**.

Removal

1. Raise and support vehicle. Remove rear wheel. Using Rear Hub Holding Tool (J-42066) and a 1/2" breaker bar, counter hold rear wheel hub and remove drive shaft bolts. Separate drive shaft from wheel hub flange and support aside. Remove brake hose clip from lower control arm and remove brake hose to allow for brake caliper removal.
2. Remove brake caliper assembly and wire aside. See **REAR BRAKE CALIPER**. Remove rotor set screw and remove rotor. See **REAR BRAKE ROTOR**. Using Socket (J-42072), back out 3 backing plate bolts about 9 revolutions (about 1/2") to allow for installation of rear wheel hub puller pin.

1997 Cadillac Catera

BRAKE SYSTEM 1997 BRAKES General Motors - Disc

3. Attach Spacer (J-42094-2) and Holding Fixture (J-42094-1) to wheel hub flange. Remove wheel hub nut. Attach Threaded Arbor (J-42094-4) to holding fixture using Thrust Bearing (J-42094-10) as a spacer. Install Threaded Driver (J-42094-3) into threaded arbor. Place Ball Head (J-42094-5) onto end of threaded driver.
4. Turn threaded driver and pull off wheel hub flange. Screw 3 Threaded Spacer Pins (J-42094-7) into backing plate. Attach holding fixture, with stem pointing upward, to threaded spacer pins. Press out wheel hub with threaded driver.

NOTE: During removal of wheel hub, wheel bearing seal may be damaged.

5. Remove wheel bearing retaining ring. Attach Bearing Remover (J-42094-6) to threaded driver. Turn threaded driver clockwise and press out wheel bearing.

Installation

1. Insert Bearing Installer (J-42094-8) through wheel bearing. Thread bearing installer into threaded driver. Turn threaded driver and pull wheel bearing in until bearing fully seats. Install wheel bearing retaining ring.
2. Insert Rear Wheel Hub Installer (J-42094-9) on shaft of threaded driver and attach holding fixture to threaded spacer pins. Ensure installer is on inner ring of wheel bearing. Remove supplied anchoring bolts from threaded arbor. Thread rear wheel hub into threaded driver.
3. To prevent binding of wheel hub during installation, ensure threaded driver is properly centered inside of wheel bearing. Adjust threaded spacer pins as necessary. While holding threaded driver, turn threaded arbor clockwise to draw wheel hub into wheel bearing.
4. Remove tool assembly from vehicle. Using drive shaft bolts, install threaded arbor, threaded driver, holding fixture, spacer and thrust bearing onto rear wheel flange. Install wheel hub flange onto wheel hub. Ensure splines are properly aligned. While counter holding wheel hub with threaded driver, turn threaded arbor clockwise to fully press wheel hub flange into wheel hub.
5. Remove all tools from wheel hub flange except holding fixture and spacer. Install and tighten wheel hub nut. See **TORQUE SPECIFICATIONS**. Remove holding fixture and spacer. Install retaining washer and peen washer to wheel hub. Using Torque Angle Meter (J-36660), tighten backing plate bolts to specification. See **TORQUE SPECIFICATIONS**. To complete installation, reverse removal procedure.

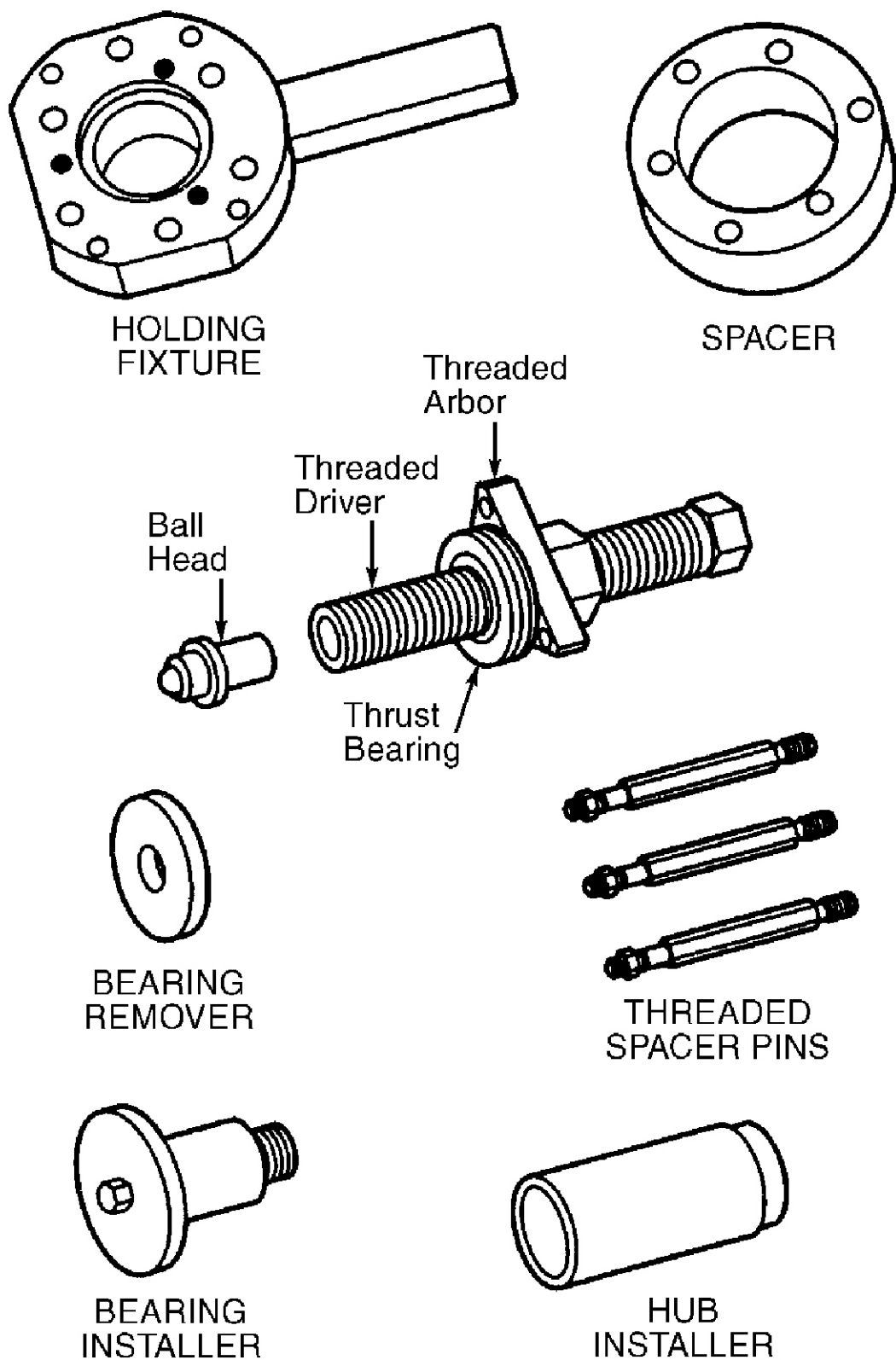

G97D03967

Fig. 4: Rear Wheel Hub & Bearing Removal & Installation Tools
Courtesy of GENERAL MOTORS CORP.

OVERHAUL

NOTE: Master cylinder and power brake booster are not serviceable. Master cylinder assembly and power brake booster assembly must be replaced as complete units.

TORQUE SPECIFICATIONS

1997 Cadillac Catera

BRAKE SYSTEM 1997 BRAKES General Motors - Disc

TORQUE SPECIFICATIONS

Application	Ft. Lbs. (N.m)
Brakeline/Brake Hose Fitting	12 (16)
Brake Hose-To-Caliper Bolt	30 (40)
Brake Pedal Bracket Nut	15 (20)
Front Brake Caliper Bracket Bolt	(1) 70 (95)
Front Brake Caliper Guide Bolt	22 (30)
Front Wheel Hub Nut	236 (320)
Master Cylinder Nut	16 (22)
Power Brake Booster Support Bracket Nut	13 (18)
Power Brake Booster Vacuum Hose Nut	13 (18)
Rear Backing Plate Bolt	(2) 37 (50)
Rear Brake Caliper Mounting Bolt	59 (80)
Rear Wheel Hub Nut	221 (300)
Wheel Lug Nut	80 (109)
	INCH Lbs. (N.m)
Caliper Bleeder Valve	80 (9)
Rotor Set Screw	35 (4)
(1) Tighten an additional 37 degrees.	
(2) Tighten an additional 40 degrees.	

DISC BRAKE SPECIFICATIONS

DISC BRAKE SPECIFICATIONS

Application	In. (mm)
Disc Diameter	
Front	11.653 (296)
Rear	11.259 (286)
Lateral Runout	.004 (.10)
Original Thickness	
Front	1.102 (28.00)
Rear	.472 (12.00)
Minimum Refinish Thickness	
Front	1.043 (26.50)
Rear	.433 (11.00)
Discard Thickness ⁽¹⁾	
Front	.984 (25.00)
Rear	.393 (10.00)
Caliper Bore	
Front	2.50 (63.5)
Rear	2.244 (57.0)
(1) Use specification stamped on rotor (if available).	

1997 Cadillac Catera

BRAKE SYSTEM 1997 BRAKES General Motors - Disc

1997 Cadillac Catera

BRAKE SYSTEM 1997 BRAKES General Motors - Disc

1997 Cadillac Catera

BRAKE SYSTEM 1997 BRAKES General Motors - Disc

1997 Cadillac Catera

BRAKE SYSTEM 1997 BRAKES General Motors - Disc

1997 Cadillac Catera

BRAKE SYSTEM 1997 BRAKES General Motors - Disc