

1997 SUSPENSION**Rear - Catera****DESCRIPTION**

Suspension consists of coil springs mounted on lower control arms, shock absorbers, stabilizer shaft, and rear axle cradle. See **Fig. 1** . Suspension is fully independent. Differential is supported by a rear axle cradle. Suspension component mounting surfaces are isolated from vehicle body and adjoining components with rubber bushings. Tie rod ends and wheel bearings are sealed and do not require lubrication.

Vehicle is also equipped with Automatic Level Control (ALC) system. ALC system automatically raises or lowers rear of vehicle to correct riding height (curb height), compensating for load added to or removed from vehicle. See **REAR - AUTOMATIC LEVEL CONTROL - CATERA** article in SUSPENSION section.

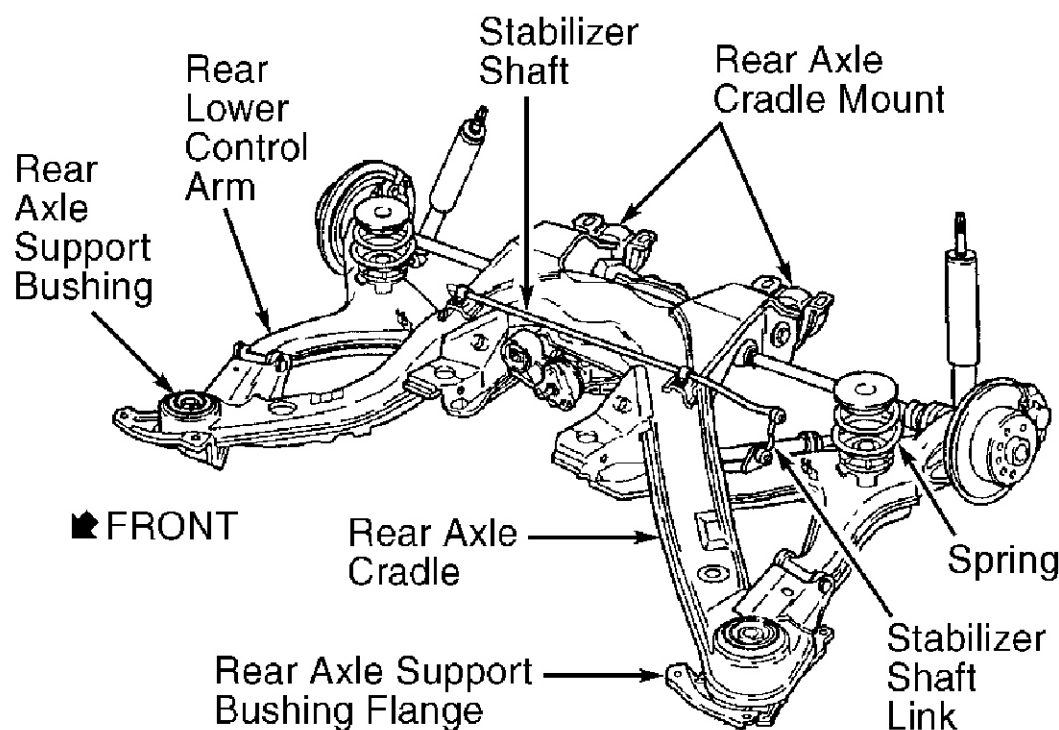

G97H03969

Fig. 1: Identifying Rear Suspension Assembly Components
Courtesy of GENERAL MOTORS CORP.

ADJUSTMENTS & INSPECTION**WHEEL ALIGNMENT**

NOTE: See **SPECIFICATIONS & PROCEDURES** article in WHEEL ALIGNMENT.

WHEEL HUB RADIAL/LATERAL RUNOUT

NOTE: Hub and bearing assemblies are pre-adjusted and pre-lubricated, and require no routine maintenance or adjustment. If faulty, replace as a complete assembly.

Raise and support vehicle. Remove wheel. Mount dial indicator to brake backing plate. Measure rear wheel hub radial runout at outer diameter of hub. Radial runout maximum should be .002" (.05 mm). Measure rear wheel hub lateral runout at front side of hub. Lateral runout maximum should be .002" (.05 mm).

RIDING HEIGHT

NOTE: For normal riding height specifications, see SPECIFICATIONS & PROCEDURES article in WHEEL ALIGNMENT.

REMOVAL & INSTALLATION

SHOCK ABSORBER

Removal

Fold rear seat forward to allow access to upper shock absorber mount. Remove protective rubber cap from shock absorber tower. Remove upper shock absorber mount nut. Remove upper mounting washer and grommet. Raise and support vehicle. Disconnect automatic level control air line connection from shock absorber. Remove lower shock absorber mount bolt and remove shock absorber.

Installation

To install, reverse removal procedure. Install upper shock absorber mount nut, and then lower mount bolt. Tighten fasteners to specification. See TORQUE SPECIFICATIONS table.

WHEEL HUB & BEARING ASSEMBLY

NOTE: See illustration for identification of tools necessary for rear wheel hub and bearing assembly removal and installation. See Fig. 2.

Removal

1. Raise and support vehicle. Remove rear wheel. Using Rear Hub Holding Tool (J-42066) and a 1/2" breaker bar, counter hold rear wheel hub and remove drive shaft bolts. Separate drive shaft from wheel hub flange and wire aside. Remove brake hose clip from lower control arm and remove brake hose to allow for brake caliper removal.
2. Remove brake caliper assembly and support aside. Remove rotor set screw and remove rotor. Using Socket (J-42072), back out 3 backing plate bolts about 9 revolutions (about 1/2") to allow for installation of rear wheel hub puller pin.
3. Attach Spacer (J-42094-2) and Holding Fixture (J-42094-1) to wheel hub flange. Remove wheel hub nut. Attach Threaded Arbor (J-42094-4) to holding fixture using Thrust Bearing (J-42094-10) as a spacer. Install Threaded Driver (J-42094-3) into threaded arbor. Place Ball Head (J-42094-5) onto end of threaded driver.

NOTE: During removal of wheel hub, wheel bearing seal may be damaged.

4. Turn threaded driver and pull off wheel hub flange. Screw 3 Threaded Spacer Pins (J-42094-7) into backing plate. Attach holding fixture with stem pointing upward to threaded spacer pins. Press out wheel hub with threaded driver.
5. Remove wheel bearing retaining ring. Attach Bearing Remover (J-42094-6) to threaded driver. Turn threaded driver clockwise and press out wheel bearing.

Installation

1. Insert Bearing Installer (J-42094-8) through wheel bearing. Thread bearing installer into threaded driver. Turn threaded driver and pull wheel bearing in until bearing fully seats. Install wheel bearing retaining ring.
2. Insert Rear Wheel Hub Installer (J-42094-9) on shaft of threaded driver and attach holding fixture to threaded spacer pins. Ensure installer is on inner ring of wheel bearing. Remove supplied anchoring bolts from threaded arbor. Thread rear wheel hub into threaded driver.

1997 Cadillac Catera

1997 SUSPENSION Rear - Catera

3. To prevent binding of wheel hub during installation, ensure threaded driver is properly centered inside of wheel bearing. Adjust threaded spacer pins as necessary. While holding threaded driver, turn threaded arbor clockwise to draw wheel hub into wheel bearing.
4. Remove tool assembly from vehicle. Using drive shaft bolts, install threaded arbor, threaded driver, holding fixture, spacer and thrust bearing onto rear wheel flange. Install wheel hub flange onto wheel hub. Ensure splines are properly aligned. While counter holding wheel hub with threaded driver, turn threaded arbor clockwise to fully press wheel hub flange into wheel hub.
5. Remove all tools from wheel hub flange except holding fixture and spacer. Install and tighten wheel hub nut. See **TORQUE SPECIFICATIONS** table. Remove holding fixture and spacer. Install retaining washer and peen washer to wheel hub. Using Torque Angle Meter (J-36660), tighten backing plate bolts to specification. See TORQUE SPECIFICATIONS table. To complete installation, reverse removal procedure.

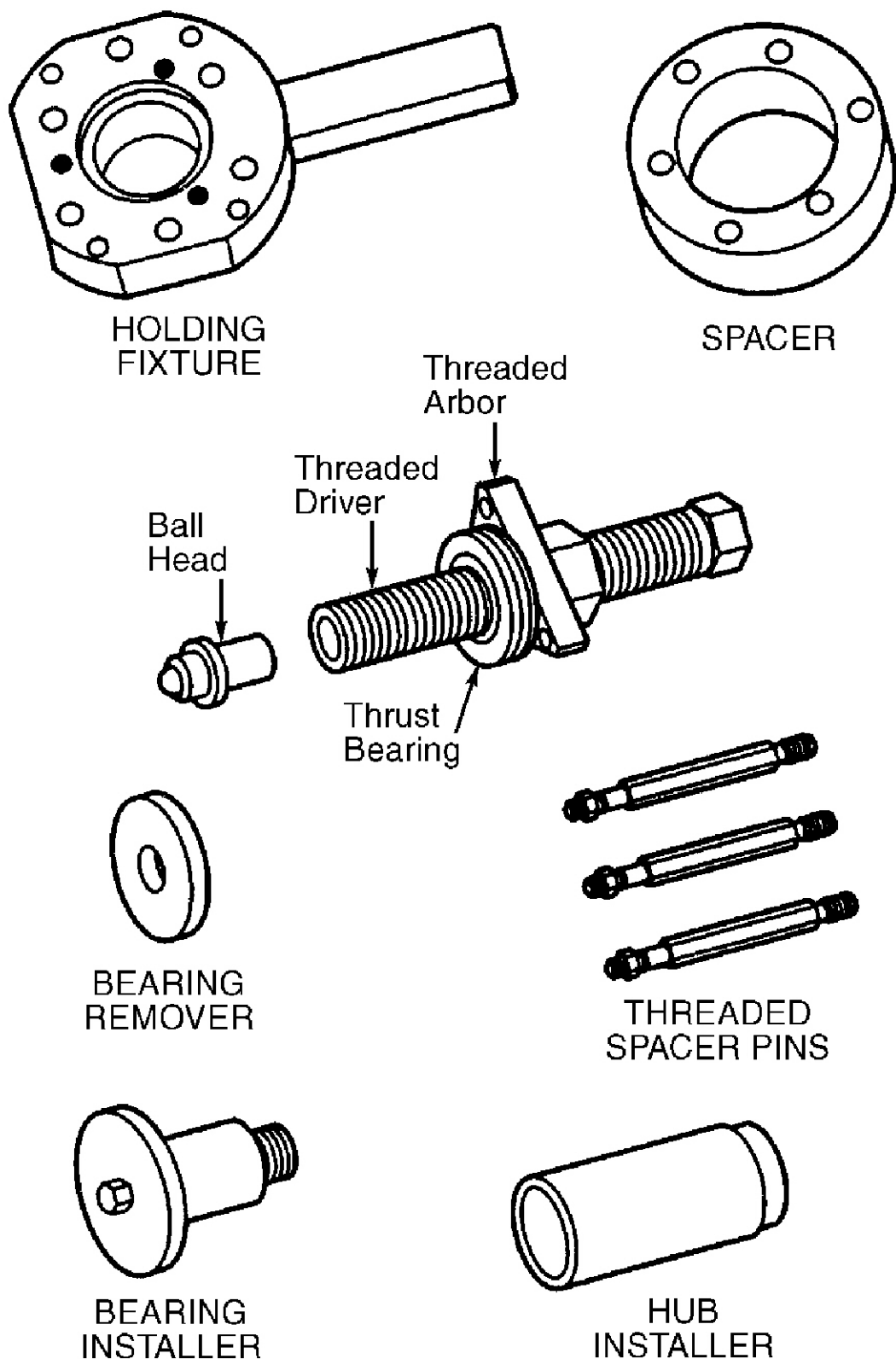

G97D03967

Fig. 2: Rear Wheel Hub & Bearing Removal & Installation Tools
 Courtesy of GENERAL MOTORS CORP.

TORQUE SPECIFICATIONS

TORQUE SPECIFICATIONS

Application	Ft. Lbs. (N.m)
Backing Plate Bolt	(1) 37 (50)
Brake Caliper Mounting Bolt	59 (80)

1997 Cadillac Catera

1997 SUSPENSION Rear - Catera

Propeller Shaft Center Bearing Bracket Bolt	15 (20)
Propeller Shaft Disc Joint-To-Rear Differential Bolt	70 (95)
Rear Axle Cradle Mount-To-Body Bolt	48 (65)
Rear Axle Cradle Mount-To-Cradle Bolt	74 (100)
Rear Axle Lower Control Arm Bolt	74 (100)
Rear Axle Support Bushing Bolt	92 (125)
Rear Axle Support Flange Bolt	48 (65)
Shock Absorber Lower Mount Bolt	81 (110)
Shock Absorber Upper Mount Nut	15 (20)
Stabilizer Shaft Link Bolt	15 (20)
Stabilizer Shaft Mounting Bracket Bolt	16 (22)
Tie Rod Adjuster Nut	11 (15)
Tie Rod Inner Bolt	66 (90)
Tie Rod Outer Nut	44 (60)
Wheel Hub Nut	221 (300)
Wheel Lug Nut	80 (109)
	INCH Lbs. (N.m)
Rotor Set Screw	35 (4)
(1) Tighten an additional 40 degrees.	

1997 Cadillac Catera

1997 SUSPENSION Rear - Catera